

stored energy solutions for a demanding world



Model: **AG12V100A**

AcmeG Series

The AcmeG range front access gel batteries is designed based on the Acme series. Using the polymer gel electrolyte with real front access structure. The state of the art internal and external design ensures AcmeG the high reliability and makes the installations quite simple and safe when placed on a standard relay rack tray or in a closed cabinet. The design float life is 12 years at 20°C(68°F).



Dimensions-mm [inch]

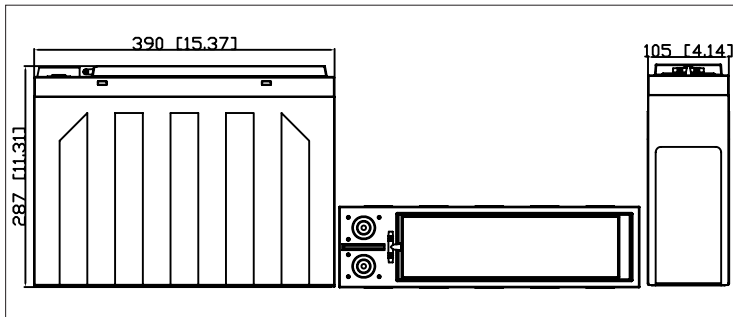

Specifications

Battery Model	AG12V100A
Nominal Voltage	12V
Rated Capacity	100Ah (10 hour rate) to 1.80V/cell @25°C(77°F)
Typical Weight	33.0kg
Internal Resistance	Approx 6.59mΩ
Temperature Ranges	Operation (maximum): -40°C to 50°C(-40°F to 122°F)
	Operation (recommended): 15°C to 25°C(59°F to 77°F)
	Storage: -20°C to 40°C(-4°F to 104°F)
Float Voltage	2.25V/cell@25°C(77°F)
Recommended Maximum Charging Current Limit	25A
Equalize and Cycle Service	2.35V~2.40V/cell@25°C(77°F)
Self Discharge	The residual capacity is above 90% after 90 days storage(25°C/77°F)
Terminal	M6 Female
Terminal Hardware Torque	8 ± 1.0Nm
Container Material	ABS (V0 optional)

Constant Current Discharge Characteristics Units: Amperes (25°C, 77°F)

End voltage per cell	5MIN	15MIN	30MIN	45MIN	1HR	2HR	3HR	4HR	5HR	6HR	8HR	10HR	12HR	20HR	24HR
1.60V	359.2	193.0	117.4	84.9	68.6	39.3	28.6	22.4	18.9	16.2	12.5	10.3	8.70	5.45	4.55
1.67V	337.3	186.1	115.4	84.2	68.2	39.1	28.1	22.3	18.8	16.1	12.4	10.2	8.69	5.40	4.51
1.70V	334.3	183.1	113.4	83.6	67.7	38.8	27.9	22.2	18.5	15.9	12.4	10.2	8.60	5.39	4.51
1.75V	307.5	177.1	112.4	83.0	66.7	37.8	27.6	21.9	18.4	15.8	12.3	10.1	8.60	5.38	4.51
1.80V	275.6	165.2	107.5	79.6	65.0	37.5	27.4	21.8	18.0	15.5	12.2	10.0	8.53	5.32	4.50
1.83V	262.7	151.2	105.5	76.9	62.1	37.0	26.5	20.8	17.4	15.0	11.9	9.61	8.11	5.31	4.43
1.85V	245.8	147.3	98.1	73.9	60.2	35.6	25.8	20.6	17.0	14.6	11.5	9.53	8.02	5.21	4.39

Discharge Data with Constant Power Units: Watts per cell (25°C, 77°F)

End voltage per cell	5MIN	15MIN	30MIN	45MIN	1HR	2HR	3HR	4HR	5HR	6HR	8HR	10HR	12HR	20HR	24HR
1.60V	601.0	339.3	211.9	159.2	129.5	74.3	54.3	43.0	36.3	31.3	24.2	19.9	16.7	10.8	8.98
1.67V	578.1	333.3	209.9	158.2	128.5	74.1	53.6	42.9	36.3	31.1	24.1	19.7	16.7	10.7	8.98
1.70V	575.1	329.3	209.9	158.2	128.5	73.8	53.6	42.7	35.8	30.9	23.9	19.5	16.6	10.7	8.96
1.75V	536.3	327.4	209.0	157.2	126.5	73.4	53.0	42.7	35.8	30.8	23.7	19.5	16.5	10.7	8.96
1.80V	492.5	309.4	204.0	154.2	125.5	73.2	52.9	42.6	35.2	30.5	23.6	19.5	16.5	10.7	8.94
1.83V	470.6	283.6	202.0	149.3	120.5	72.3	51.6	41.0	34.4	29.6	23.4	19.0	16.0	10.7	8.88
1.85V	439.8	276.6	187.1	143.3	116.5	69.9	50.2	40.5	33.6	29.0	22.7	18.8	15.8	10.5	8.81

stored energy solutions for a demanding world

NARADA

Model: **AG12V100A**

AcmeG Series

Terminal Voltage(V) Vs. Discharge Time (25°C, 77°F)

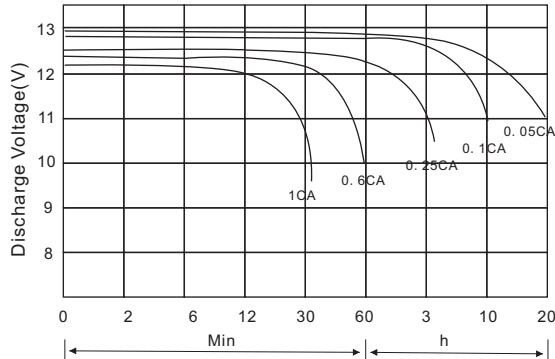

Battery Voltage Vs. Charge Time

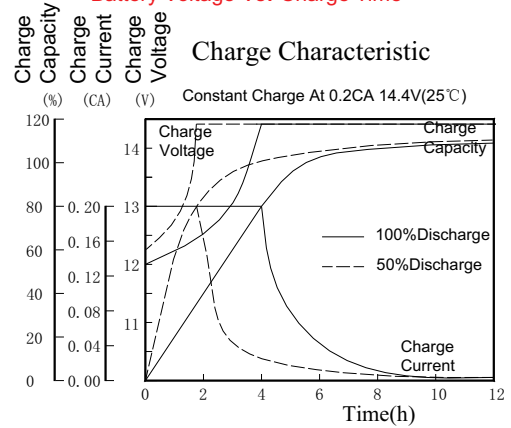

Relationship of OCV Vs. State of Charge

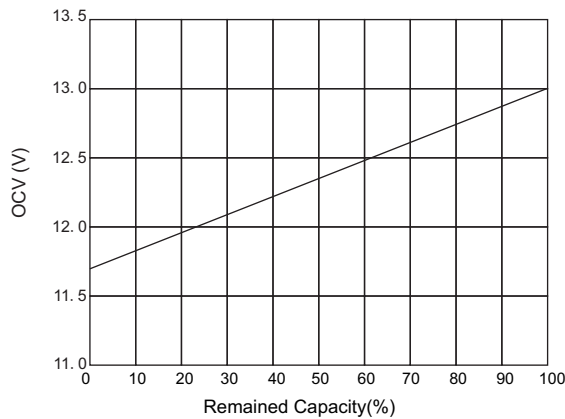

Capacity Retention Characteristic

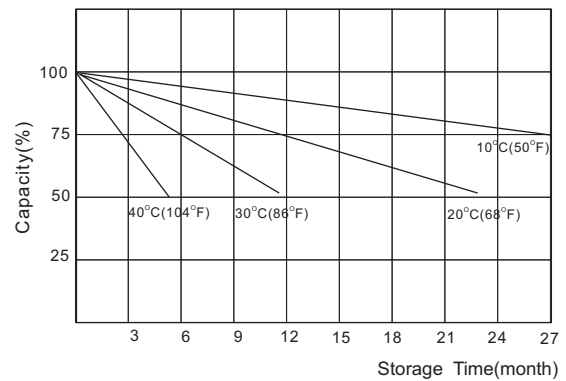

Charging Procedures

Application	Charge Voltage (V/Cell)			Max. Charge Current
	Temperature	Set Point	Allowable Range	
Cycle	25°C	2.40	2.35~2.40	0.25C
Standby	25°C	2.25	2.23~2.27	

Discharge Current VS. Discharge Voltage

Final Discharge Voltage V/Cell	1.80	1.70	1.55	1.30
Discharge Current (A)	0.2C ≥ (A)	0.2C < (A) < 0.5C	0.5C < (A) < 1.0C	(A) > 1.0C

NARADA POWER SOURCE CO.,LTD.

9F, Building A, No. 50 Zijinghua Road, Hangzhou, China
 Tel:+86-571-28827013 Fax:+86-571-28828290
 Website:www.naradabattery.com E-mail: intl@narada.biz

NARADA ASIA PACIFIC PTE.LTD.

65 Ubi Crescent #07-05 HOLA centre, Singapore
 Tel: +65-6848 1191 Fax: +65-6749 3498
 E-mail: sales@narada.com.sg

NARADA EUROPE (UK) LIMITED

Spectrum House, Dunstable Road, Redbourn,
 St. Albans, Herts AL3 7PR
 Tel: +44 (0)845 371 7095 Fax:+44 (0)845 612 2031
 E-mail: sales@naradaeurope.com



TEMPEL GROUP ARGENTINA
 www.tempelgroup.com
 baires@tempelgroup.com
 Tel.+54 11 4897-7184/7178

TEMPEL GROUP en el mundo

BUENO AIRES · MADRID · VALENCIA · BILBAO · SEVILLA · LISBOA · PORTO · LIMA · SÃO PAULO · SANTIAGO DE CHILE · BOGOTÁ · CIUDAD DE MÉXICO · CIUDAD DE PANAMÁ · MONTEVIDEO · QUITO



AG12V100A-03-N-EN (Ver.03 July 2012) Subject to revision without prior notice. E & O.E.