

Designed and manufactured with 8 exclusive patented technologies, Narada have created an innovative range of high temperature batteries. The 313K series is designed to cope with the most extreme temperatures and environments. The advanced technology and unique manufacturing methods enable 313K batteries to deliver at least twice the cycle life of conventional lead- acid batteries, making them the first choice increasing power demands in remote hybrid telecom sites and other tough off-grid applications.

Standards

Test standards

IEC60896-21/-22 , IEC61427 , YD/T 799 etc .

Safety standard , ventilation

EN 50272- 2

Manufactured under system

ISO9 001 /TL9000 & ISO1400 1 by Narada

Benefits

- Excellent deep cycling capability
- Suitable for continuous operation at temperatures in excess of 35°C
- Reduced system operating costs
- 25% electricity power saving
- Up to 100% air conditioner maintenance saving
- Up to 100% condensing agent saving
- 30% CO2 gas emission reduce
- Less than 1 year payback period depend on environment



Technical specifications

Electrical data	
Nominal voltage	2 V
Number of cells	1
Rated capacity	1200Ah -120A for 10h to 1.80V/cell(25°C) 1263Ah - 126.3A for 10h to 1.80V/cell(35°C)
Internal resistance	0.14mΩ(acc.to IEC 60896-21)
Short circuit current	13847 A(acc.to IEC 60896-21)
Self discharge(35°C)	less than 5% per month
Design life at 35°C	15 years
Mechanical data	
Weigh ready for use	90 kg(198.4 lbs)
Length	232mm(9.13 in)
Width	263mm(10.35 in)
Height of monobloc	502mm(19.76 in)
Total height	514mm(20.24 in)
Terminal	M8 female
Terminal hardware torque	1 0 -12Nm

Constant Current Discharge Data Units:Amperes(35°C,95°F)

End Voltage	15 min	30 min	60 min	3 hour	5 hour	8 hour	10 hour	24 hour	48 hour	72 hour	120 hour	240 hour
1.75V	1252.7	933.7	677.5	327.8	223.4	153.4	128.0	57.6	29.5	20.2	12.8	6.59
1.80V	1168.2	874.2	643.5	320.6	218.3	150.6	126.3	56.4	29.1	19.9	12.6	6.51
1.83V	1075.3	815.9	607.1	310.8	214.9	149.6	125.7	56.4	29.0	19.8	12.5	6.48
1.85V	993.7	768.6	568.2	294.1	204.6	144.5	121.1	54.8	27.9	19.1	12.2	6.30
1.88V	898.8	711.5	516.0	277.2	195.0	139.1	116.6	53.2	26.8	18.4	11.6	6.01
1.90V	784.5	638.7	469.9	262.7	185.3	131.0	110.4	51.2	25.4	17.4	11.0	5.68

Constant Power Discharge Data Units:Watts per cell(35°C,95°F)

End Voltage	5 min	15 min	30 min	60 min	90 min	2 hour	3 hour	4 hour	5 hour	6 hour	8 hour	10 hour	12 hour	24 hour
1.70V	2819.7	2398.0	1953.7	1428.1	1089.0	897.3	690.3	556.7	470.4	413.2	339.1	282.0	235.0	123.4
1.75V	2704.3	2294.7	1836.8	1346.7	1025.8	858.1	677.0	546.9	461.9	401.1	331.8	279.5	233.0	122.1
1.80V	2582.7	2163.4	1716.7	1239.7	963.8	826.5	656.3	538.4	449.7	392.6	324.5	274.7	228.9	120.3
1.83V	2430.8	2023.6	1604.3	1159.5	917.6	796.1	641.7	523.8	437.5	381.6	316.0	269.8	224.8	118.5
1.85V	2277.3	1889.9	1482.8	1062.3	862.9	765.7	619.9	509.3	425.4	370.7	306.0	260.1	216.7	115.5
1.88V	2123.9	1736.5	1336.9	972.3	826.5	726.8	585.8	488.6	413.2	362.2	297.8	252.8	210.7	112.4
1.90V	1914.2	1531.4	1212.4	900.6	777.9	690.3	565.2	471.6	397.4	350.0	286.8	244.8	204.0	108.2
1.94V	1731.9	1399.2	1071.1	811.9	708.6	635.7	517.2	429.6	362.2	314.8	257.7	220.5	183.7	107.0

Construction

Positive plate	Reinforced grids in a corrosion-resistant pure lead, high tin, low calcium alloy
Negative plate	Lead-calcium alloy grid
Separator	High density microporous glass mat with low electrical resistance
Container & lid	High temperature ABS. Optional flame retardant versions available (UL94FV-0 with L.O.L of 28%)
Electrolyte	Sulphuric acid with a density of 1.28g/ml absorbed in AGM
Terminal design	Patented leak resistant seal configuration with brass insert
Safety valve	Calibrated opening pressure, the valve equipped with flame arrestors for increased operational safety and service life

Installation and operation

- Recommended float charge voltage compensation in function of temperature: 2.24V per cell at 35°C -3mV/°C/cell
- Cycle and equalize charge voltage: 2.30V per cell at 35°C, or case by case compensation in function of temperature: -5mV/°C/cell
- CC-CV charge current: unlimited, otherwise 0.25C10A max. if T>25°C
- Preferred operating temperature range: 15°C to 35°C (68°F to 95°F)
- Maximum operating temperature range: -40°C to 80°C (-40°F to 176°F)
- A separate battery room: is not necessary
- Reduced maintenance: no water addition required

Racking (optional)

Narada racks are constructed using strong, easy to assemble, powder-coated steel tubing and come complete with sliding cover terminal (take-off) plates.

Cell model:	HTB-1200	
Number of cells:	24	
System Voltage:	48	
Cell Configuration	4 high 6 wide	In outdoor cabinet
Rack width (mm)	1650	Cabinet width (1520)
Rack depth (mm)	511.5	Cabinet depth (1710)
Rack height (mm)	1336	Cabinet height (1520)
System weight (kg)	2236	2560

*Please allow 100mm for terminal boxes

Dimensions (mm)

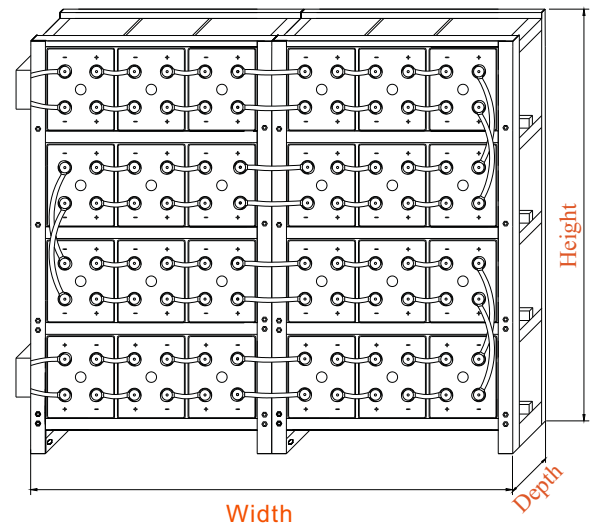
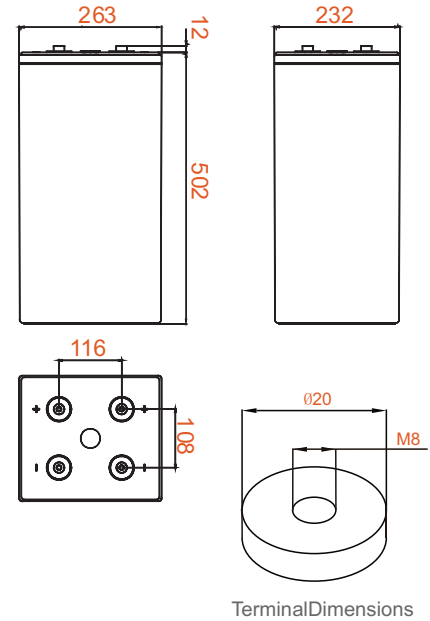

NARADA POWER SOURCE CO., LTD.
9F, Building A, No. 50 Zijinghua Road, Hangzhou, China
Tel: +86-571-28827013 Fax: +86-571-28828290
Website: www.naradabattery.com E-mail: intl@narada.biz

NARADA ASIA PACIFIC PTE. LTD.
65 Ubi Crescent #07-05 Ubi Centre, Singapore
Tel: +65-6848 1191 Fax: +65-6749 3498
E-mail: sales@narada.com.sg

NARADA EUROPE (UK) LIMITED
Spectrum House, Dunstable Road, Redbourn,
St. Albans, Herts AL3 7PR
Tel: +44 (0)845 371 7095 Fax: +44 (0)845 612 2031
E-mail: sales@naradaeurope.com

