

Designed and manufactured with 8 exclusive patented technologies, Narada have created an innovative range of high temperature batteries. The 313K series is designed to cope with the most extreme temperatures and environments. The advanced technology and unique manufacturing methods enable 313K batteries to deliver at least twice the cycle life of conventional lead- acid batteries, making them the first choice increasing power demands in remote hybrid telecom sites and other tough off-grid applications.

Standards

Test standards

IEC60896-21/-22, IEC61427, YD/T799 etc.

Safety standard, ventilation

EN 50272-2

Manufactured under system

ISO9001/TL9000& ISO 14001 by Narada

313K Series

High Temperature Batteries

Benefits

- Excellent deep cycling capability
- Suitable for continuous operation at temperatures in excess of 35°C
- Reduced system operating costs
- 25% electricity power saving
- Up to 100% air conditioner maintenance saving
- Up to 100% condensing agent saving
- 30% CO2 gas emission reduce
- Less than 1 year payback period depend on environment



Technical specifications

Electrical data	
Nominal voltage	2 V
Number of cells	1
Rated capacity	500Ah -50A for 10h to 1.80V/cell(25°C)
	525Ah - 52.5A for 10h to 1.80V/cell(35°C)
Internal resistance	0.28mΩ(acc.to IEC 60896-21)
Short circuit current	7211 A(acc.to IEC 60896-21)
Self disc charge(35°C)	less than 5% per month
Design life at 35°C	15years
Mechanical data	
Weigh ready foruse	39 kg(68.0 lbs)
Length	231mm(9.09 in)
Width	155mm(6.10 in)
Height of monobloc	395mm(15.55 in)
Total height	407mm(16.02 in)
Terminal	M8 female
Terminal hardware torque	1.0 -12Nm

Constant Current Discharge Date Units:Amperes(35°C,95°F)

End Voltage	15 min	30 min	60 min	3 hour	5 hour	8 hour	10 hour	24 hour	48 hour	72 hour	120 hour	240 hour
1.75V	590.2	432.6	288.4	132.5	92.1	64.5	53.8	24.0	12.3	8.47	5.38	2.76
1.80V	556.5	404.7	270.2	128.5	90.0	63.2	52.5	23.6	12.1	8.28	5.30	2.73
1.83V	522.5	385.3	253.0	124.3	87.8	62.1	51.4	23.1	11.8	8.10	5.20	2.68
1.85V	493.5	360.9	243.9	121.9	86.9	61.4	51.1	22.7	11.7	8.06	5.11	2.63
1.88V	450.0	339.0	233.6	119.4	86.0	60.7	50.7	22.5	11.6	7.99	5.00	2.57
1.90V	417.3	309.6	216.5	114.3	83.7	59.1	49.4	22.2	11.4	7.78	4.94	2.54

Constant Power Discharge Date Units:Wants per cell(35°C,95°F)

End Voltage	5 min	15 min	30 min	60 min	90 min	2 hour	3 hour	4 hour	5 hour	6 hour	8 hour	10 hour	12 hour	24 hour
1.70V	1325.1	1123.4	891.3	606.0	476.0	395.8	283.0	228.5	194.8	167.4	129.9	106.6	97.0	48.8
1.75V	1283.8	1081.2	860.9	582.4	461.7	381.8	272.6	223.7	190.0	163.6	125.1	105.0	95.6	48.3
1.80V	1248.3	1030.6	830.5	568.9	450.7	374.7	263.0	216.5	184.7	158.8	121.9	103.4	94.1	47.6
1.83V	1179.9	983.3	783.3	548.6	435.5	359.6	256.6	213.3	180.9	154.0	119.5	101.4	92.3	46.9
1.85V	1135.2	938.6	738.5	517.4	418.3	344.4	249.0	208.2	176.1	150.3	117.9	99.4	90.5	45.7
1.88V	1071.9	869.3	686.7	486.2	386.6	320.1	240.5	201.0	170.3	145.0	114.7	97.0	88.3	44.5
1.90V	1001.9	814.5	622.9	445.6	358.5	298.8	230.9	193.8	164.5	140.5	110.3	92.2	84.0	42.8
1.94V	905.6	729.2	558.1	395.0	321.1	276.1	214.6	181.5	155.9	134.7	105.8	88.2	80.6	42.3

Construction

Positive plate	Reinforced grids in a corrosion-resistant pure lead, high tin, low calcium alloy
Negative plate	Lead-calcium alloy grid
Separator	High density microporous glass mat with low electrical resistance
Container & lid	High temperature ABS. Optional flame retardant versions available (UL94 FV-0 with L.O.I. of 28%)
Electrolyte	Sulphuric acid with a density of 1.28g/ml absorbed in AGM
Terminal design	Patented leak resistant seal configuration with brass insert
Safety valve	Calibrated opening pressure, the valve equipped with flame arrestors for increased operational safety and service life.

Dimensions (mm)

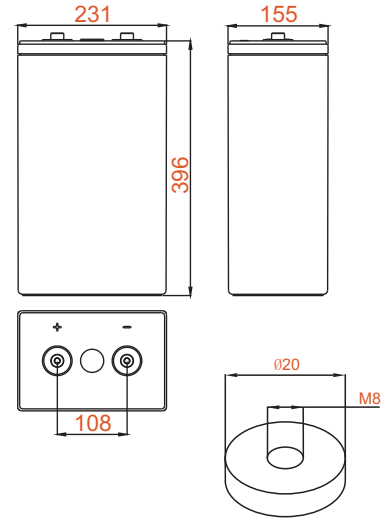

terminal Dimensions

Installation and operation

- Recommended float charge voltage: 2.24V per cell at 35°C
- compensation in function of temperature: -3mV/°C/cell
- Cycle and equalize charge voltage: 2.30V per cell at 35°C, or case by case
- compensation in function of temperature: -5mV/°C/cell
- CC-CV charge current: unlimited, otherwise 0.25C10 Amax. if T > 25°C
- Preferred operating temperature range: 15°C to 35°C (68°F to 95°F)
- Maximum operating temperature range: -40°C to 80°C (-40°F to 176°F)
- A separate battery room: is not necessary
- Reduced maintenance: no water addition required.

Racking (optional)

Narada racks are constructed using strong, easy to assemble, powder-coated steel tubing and come complete with sliding cover terminal (take-off) plates.

Cell model:	HTB-500		
Number of cells:	24		
System Voltage:	48		
Cell Configuration	4 high 6 wide	6 high 4 wide	In outdoor cabinet
Rack width (mm)	1646	1064	Cabinet width (1200)
Rack depth (mm)	405	405	Cabinet depth (1450)
Rack height (mm)	900	1300	Cabinet height (1500)
System weight (kg)	1044	1032	1185

* Please allow 100 mm for terminal boxes

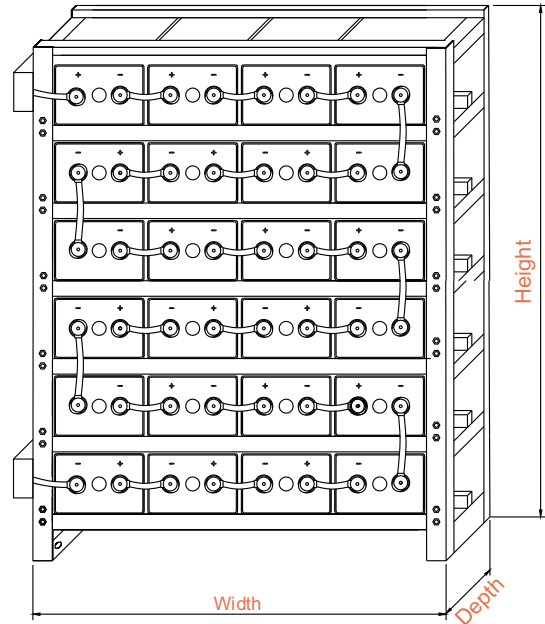

NARADA POWER SOURCE CO.,LTD.
9F, Building A, No. 50 Zijinghua Road, Hangzhou, China
Tel: +86-571-28827013 Fax: +86-571-28828290
Website: www.naradabattery.com E-mail: intl@narada.biz

NARADA ASIA PACIFIC PTE.LTD.
65 Ubi Crescent #07-05 Ubi centre, Singapore
Tel: +65-6848 1191 Fax: +65-6749 3498
E-mail: sales@narada.com.sg

NARADA EUROPE (UK) LIMITED
Spectrum House, Dunstable Road, Redbourn,
St. Albans, Herts AL3 7PR
Tel: +44 (0)845 371 7095 Fax: +44 (0)845 612 2031
E-mail: sales@naradaeurope.com

