

Renewable Energy Storage Batteries

Features & Benefits

- Long life design for both cyclic and float applications
- Superb security and reliability
- Robust design inside and out
- Excellent deep discharge recovery fast recharge performance
- Extra long back-up times
- More cost effective than nearest equivalent



Narada's REX battery is designed for Renewable Energy Sources such as Solar and Wind Power. REX protects our environment using Green Technology and benefits the World's Urban and Rural Population by Generating Power Economically from a Clean Source of Energy. REX is a product developed by Narada's R&D with an "eXtra" in Performance and Life Span.

Standards

Test standards

IEC60896-21/-22, IEC61427, YD/T 799 etc.

Safety standard, ventilation

EN 50272-2

Manufactured under system

ISO9001/TL9000 & ISO14001 by Narada

Technical specifications

Electrical data

Nominal voltage	2 V
Number of cells	1
Rated capacity(25°C)	600 Ah - 60A for 10h to 1.80V/cell 720 Ah - 6A for 120h to 1.85V/cell
Internal resistance	0.23 mΩ (acc. to IEC 60896-21)
Short circuit current	8614 A (acc. to IEC60896-21)
Self discharge(25°C)	less than 2% per month
Design life at 20°C	20 years

Mechanical data

Weight ready for use	48 kg (105.8 lbs)
Length	231 mm (9.09 in)
Width	180 mm (7.09 in)
Height of monobloc	396 mm (15.59 in)
Total height	408 mm (16.06 in)
Terminal	M8 female
Terminal hardware torque	10 - 12 Nm

Constant Current Discharge Data Units: Amperes (25°C,77°F)

End Voltage	Time (minutes)		Time (hours)										
	15	30	1	3	5	8	10	12	20	24	48	72	120
1.70V	734	548	356	161	111	76.8	64.2	54.4	33.2	28.5	14.8	10.1	6.42
1.75V	694	509	339	156	108	75.8	63.2	53.6	32.9	28.2	14.6	9.96	6.32
1.80V	655	476	318	151	106	74.4	61.8	52.3	32.3	27.7	14.2	9.74	6.18
1.83V	615	453	298	146	103	73.1	60.5	51.4	31.7	27.1	13.9	9.53	6.10
1.85V	581	425	287	143	102	72.3	60.1	51.1	31.3	26.8	13.8	9.48	6.01
1.90V	491	364	255	135	98.4	69.5	58.1	49.6	30.6	26.2	13.4	9.16	5.81

Constant Power Discharge Data Units: Watts per cell (25°C,77°F)

End Voltage	Time (minutes)		Time (hours)										
	15	30	1	2	3	4	5	6	7	8	10	12	24
1.70V	1322	1049	713	466	333	269	229	197	172	153	125	114	58.0
1.75V	1272	1013	685	449	321	263	224	192	167	147	124	112	57.2
1.80V	1212	977	669	441	309	255	217	187	162	143	122	111	56.3
1.83V	1157	921	645	423	302	251	213	181	158	141	119	109	55.2
1.85V	1104	869	609	405	293	245	207	177	155	139	117	106	54.1
1.90V	958	733	524	352	272	228	194	165	147	130	108	98.8	50.2

Construction

Positive plate	Reinforced grids in a corrosion-resistant pure lead, high tin, low calcium alloy
Negative plate	Lead-calcium alloy grid
Separator	High density microporous glass mat with low electrical resistance
Container & lid	High strength ABS(HB). Optional flame retardant versions available (UL94 FV-0 with L.O.I. of 28%)
Electrolyte	Sulphuric acid with a density of 1.28g/ml absorbed in AGM
Terminal design	Patented leak resistant seal configuration with brass insert
Safety valve	Calibrated opening pressure, the valve equipped with flame arrestors for increased operational safety and service life.

Installation and operation

- Recommended float charge voltage compensation in function of temperature: 2.27V per cell at 25°C -3mV/°C/cell
- Cycle and equalize charge voltage: compensation in function of temperature: 2.35V per cell at 25°C -5mV/°C/cell
- CC-CV charge current: unlimited, otherwise 150A max. if T>25°C
- Preferred operating temperature range: 15°C to 25°C (68°F to 77°F)
- Maximum operating temperature range: -40°C to 50°C (-40°F to 122°F)
- A separate battery room is not necessary
- Reduced maintenance: no water addition required.

Dimensions (mm)

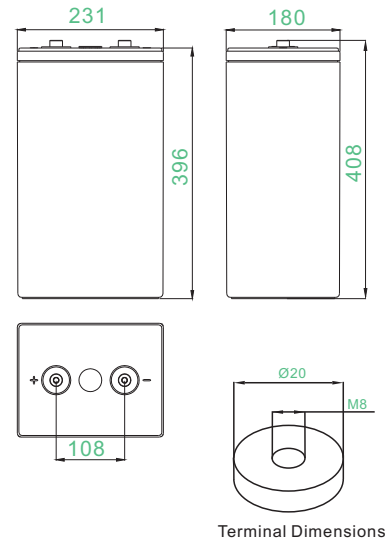

Racking (optional)

Narada racks are constructed using strong, easy to assemble, powder-coated steel tubing and come complete with sliding cover terminal (take-off) plates.

Cell model: REX-600
 Number of cells: 24
 System Voltage: 48

Cell Configuration	2 high 12 wide	4 high 6 wide	6 high 4 wide
Rack width* (mm)	3160	1615	1135
Rack depth (mm)	460	460	460
Rack height (mm)	550	1000	1450
System weight (kg)	1225	1222	1230

* Please allow 100mm for terminal boxes

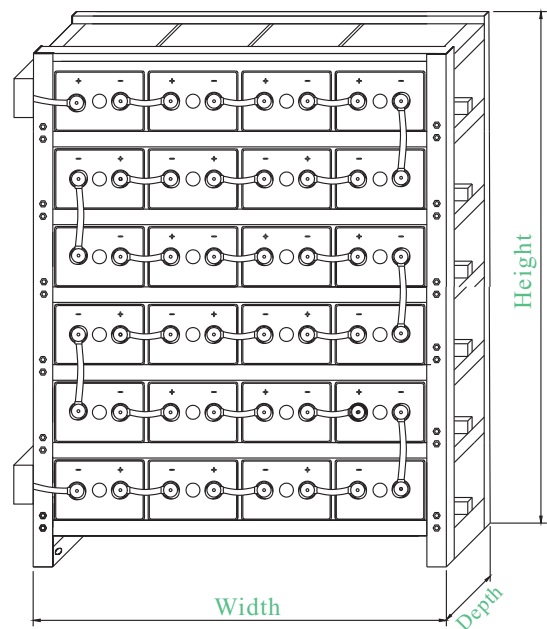

NARADA POWER SOURCE CO.,LTD.
 No.459 Wensan Road, Hangzhou, Zhejiang, P.R.China
 Tel:+86-571-28827013 Fax:+86-571-85126942
 Website:www.naradabattery.com E-mail: intl@narada.biz

NARADA ASIA PACIFIC PTE.LTD.
 65 Ubi Crescent #07-05 HOLA centre, Singapore
 Tel: +65-6848 1191 Fax: +65-6749 3498
 E-mail: sales@narada.com.sg

NARADA EUROPE (UK) LIMITED
 Spectrum House, Dunstable Road, Redbourn,
 St. Albans, Herts AL3 7PR
 Tel: +44 (0)845 371 7095 Fax: +44 (0)845 612 2031
 E-mail: sales@naradaeurope.com

